



FENDER FLARES

Assembly, Installation, Operation,
and Maintenance Instructions

PART NUMBER	TFC3003OE
INSTALL TIME	2-3 HOURS

VEHICLE FITMENT

VEHICLES	2007-2013 CHEVROLET SILVERADO 1500
BED LENGTH	COMPATIBLE WITH 5'7" BED LENGTH ONLY

DEALER / INSTALLER	Provide a copy of these instructions to the end user of this product. These instructions provide important operating and safety information. Demonstrate the proper use of the product with the end user. Have the end user demonstrate that they understand the proper use of the product.
---------------------------	---

END USER	Read and follow all instructions included in this manual. Ask your Dealer/Installer for assistance if you do not understand the proper use of the product. Never remove any informational or warning labels from the product. Failure to follow these instructions can result in injury or death.
-----------------	---

TOOLS REQUIRED (NOT INCLUDED)

UTILITY KNIFE	#2 PHILLIPS DRIVE BIT
7mm SOCKET	SOCKET WRENCH
GREASE PENCIL OR MARKER	1/2" WRENCH

PACKAGE CONTENTS

ITEM	PART DESCRIPTION	QTY
1	LEFT & RIGHT FRONT FLARES	1
2	LEFT & RIGHT REAR FLARES	1
3	EDGE TRIM TOOL	1
4	RUBBER EDGE TRIM	1
5	U-CLIPS	4
6	S-CLIPS	8
7	1" X 1" BLACK TABS	8
8	#10 X 5/16" TRUSS HEAD SCREWS	8
9	#14 X 3/4" TRUSS HEAD SCREWS	4

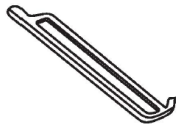
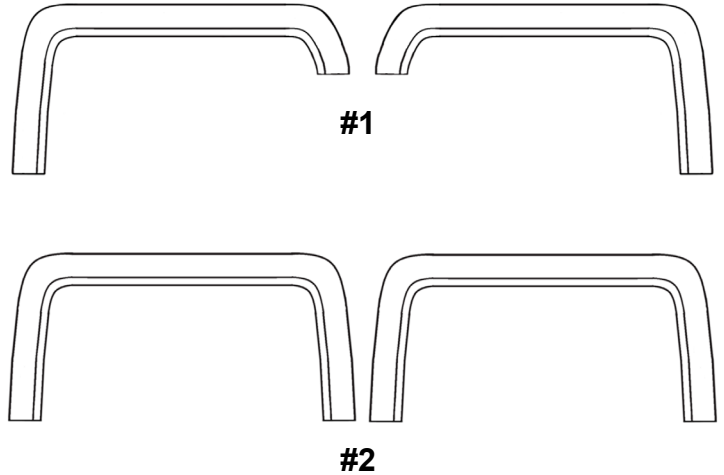

#3



#4



#5



#6



#7



#8

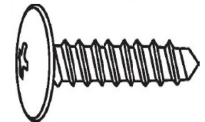

#9

WARNINGS/SAFETY PRECAUTIONS



Use safety glasses and gloves as necessary when operating power tools.

Dirt and debris may become lodged between the fender flares and the vehicle's fenders, causing scratching and paint wear from vibrations. Keystone Automotive Operations, Inc. is not responsible for any vehicle damage, and customer accepts all associated risks.

Do not over-tighten any screws. Over-tightening may result in stress fractures in the fender flares.

PRIOR TO INSTALLATION:

Thoroughly clean installation area on the vehicle.

Verify contents of box.

Read instructions thoroughly.

Use caution to avoid scratching the fender flare and vehicle.

Verify proper fitment of fender flares to the vehicle. If the vehicle has oversized tires, ensure that the fender flares will not interfere with the tires. It may be necessary to lower bump stops or install steering stops.

Do not use alternative installation methods or materials, such as superglue or Loctite.

If applicable, remove existing fender flares and mud flaps.

Verify that installed fender flares will maintain at least 4 inches of clearance from exhaust pipes. Exhaust gases that discharge onto fender flare surfaces will cause heat distortion and may require modifications to remedy.

PAINTING (OPTIONAL):

NOTE: Painting is optional and should only be attempted on fender flares with smooth outer surfaces. Fender flares with textured outer surfaces should not be painted. Painted fender flares cannot be returned.

1. Clean fender surface with a high-quality degreaser.

NOTE: Do not use any solvent-based product such as lacquer thinner.

2. Wipe surface thoroughly with a tack rag.

3. Paint fender flares with a high-quality paint lacquer, enamel, or polyurethane automotive paint.

4. If painting edge trim (not recommended), use a flex additive.

EDGE TRIM INSTALLATION

1. Peel 2-3 inches of red tape liner away from the edge trim tape (#4). Apply the adhesive surface of the edge trim to the inner surface of the flare. Install edge trim to the outside perimeter of the fender flare (the portion that physically contacts the vehicle). **(IMAGE 1)**
2. Press the edge trim into place along the top edge of the fender flare while simultaneously pulling away the red tape liner. Continue to work along the entire outside perimeter of the fender flare. **(IMAGE 2)**

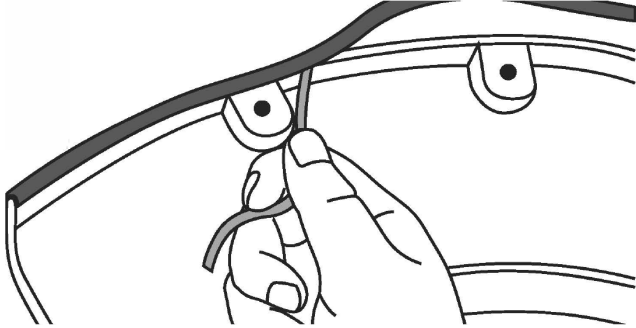

(IMAGE 1)

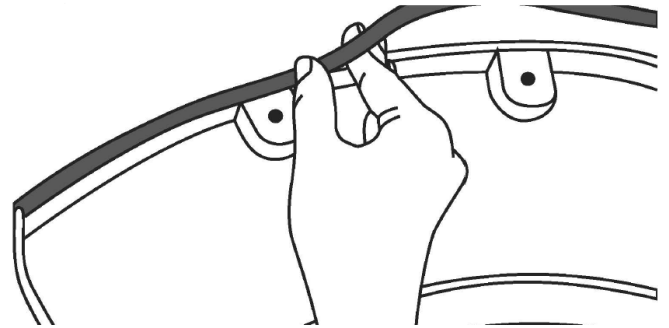

(IMAGE 2)

3. Cut the rubber edge trim to length when the installation is complete.
4. Repeat steps 1-3 for each fender flare.

FRONT FLARE INSTALLATION

1. Remove and save four (4) original factory bolts using a 7mm socket. These bolts are located where indicated. **(IMAGE 3)**

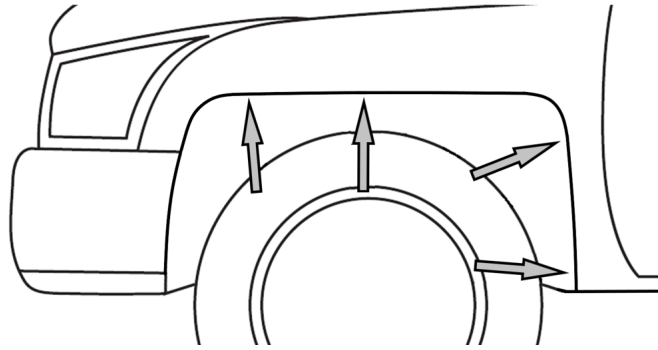

(IMAGE 3)

2. Position the front fender flare (#1) in place to line up the holes on the flare with the original vehicle holes. Reinstall four original factory bolts that were saved during step 1.
3. Verify fit and tighten all screws. **(IMAGE 4)**

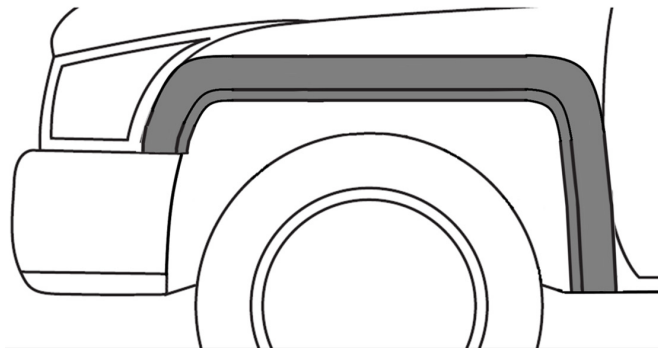

(IMAGE 4)

4. Repeat steps 1-3 for the remaining front fender flare.

REAR FLARE INSTALLATION

1. Hold the flare in position against the vehicle with moderate pressure. Using a marker or grease pencil, mark the six clip positions where each indicated fender flare hole is located along the lip of the wheel well. **(IMAGE 5)**
2. Remove the flare and install a 1" x 1" black tab (#7) centered over each of the four locations marked with a star. **(IMAGE 5)**
3. Slide a U-clip (#5) onto each of the two uppermost marked holes. **(IMAGE 6, 7)**
4. Slide an S-clip (#6) onto each of the four 1" x 1" black tabs. **(IMAGE 5, 8)**

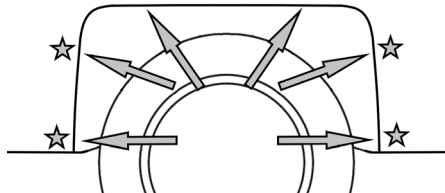

(IMAGE 5)

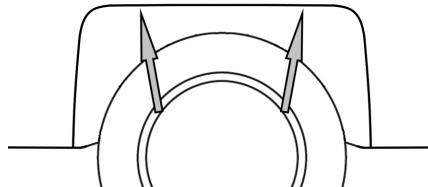

(IMAGE 6)

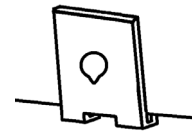

(IMAGE 7)

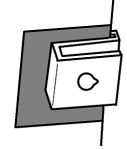

(IMAGE 8)

5. Hold the fender flare in position and loosely install #14 x 3/4" truss head screws (#9) through the two topmost holes in the rear fender flare (#2) and through the aligned U-clips (#5). **(IMAGE 9)**
6. Loosely install #10 x 5/16" truss head screws (#8) through the remaining four flare holes and through the S-clips. **(IMAGE 10)**

NOTE: U-clips and S-clip positions may need to be adjusted to align with the holes in the flare.

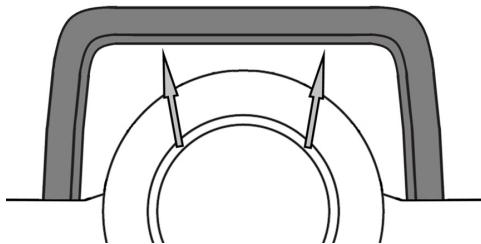

(IMAGE 9)

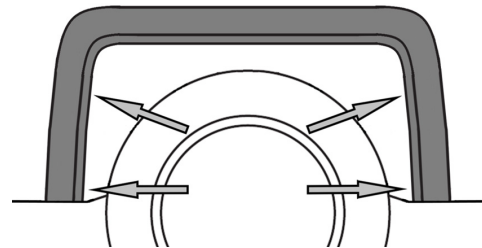

(IMAGE 10)

7. Tighten all screws evenly while pressing in on the flare to ensure that it is positioned properly against the vehicle body panels and the lip of the wheel well.
8. Repeat steps 1-7 for the remaining rear fender flare.

NOTE: The edge trim tool (#3) may be used after fender flare installation is complete to improve fitment as illustrated. **(IMAGE 11, 12)**

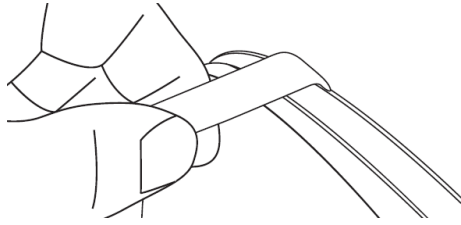

(IMAGE 11)

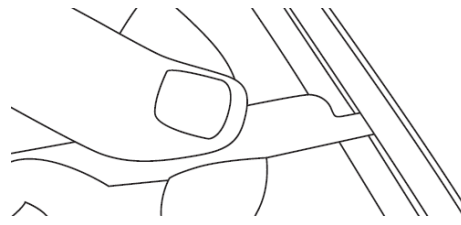

(IMAGE 12)

WARRANTY INFORMATION

Limited Lifetime Warranty:

Keystone Automotive Operations (KAO) warrants this product to be free of defects in material and workmanship at the time of purchase by the original retail consumer. KAO disclaims any other warranties, express or implied, including the warranty of fitness for a particular purpose or an intended use. If the product is found to be defective, KAO may replace or repair the product at our option, when the product is returned prepaid, with proof of purchase. Alteration to, improper installation, or misuse of this product voids the warranty. KAO's liability is limited to repair or replacement of products found to be defective, and specifically excludes liability for any incidental or consequential loss or damage.

CONTACT US

WEBSITE: TrailFX.com

PHONE: 1-866-638-4870

EMAIL: support@trailfx.com